

35 Series

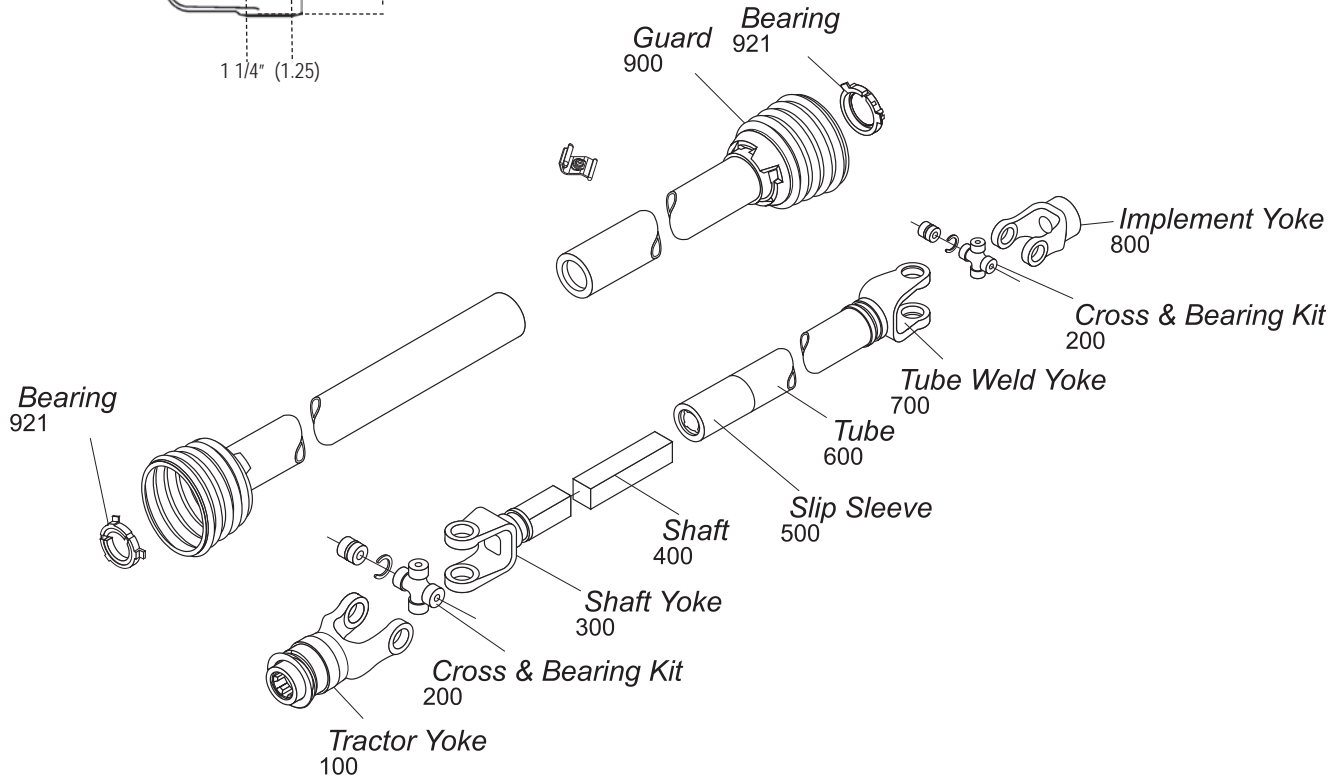

Tractor Yoke

Safety Slide Lock

Repair Kit —
*13004000
**13004020

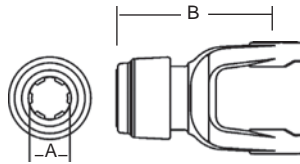

Stock Number	Dim. "A" Bore	Dim. "B"
101-3506*	1 3/8" x 6 Spl.	5 1/4"
101-3520**	1 3/4" x 20 Spl.	6 1/8"
101-3521*	1 3/8" x 21 Spl.	5 1/4"

Ball Shear Device

With Safety Slide Lock
Repair Kit —
*13004000
**13004020

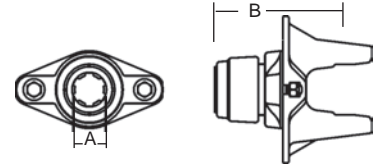

Stock Number	Dim. "A" Bore	Shear Bolt	Dim. "B"
104-3506*	1 3/8" x 6 Spl.	(2) 3/8" - 16 Gr. 5	5 1/2"
104-3520**	1 3/4" x 20 Spl.	(2) 3/8" - 16 Gr. 5	6"
104-3521*	1 3/8" x 21 Spl.	(2) 3/8" - 16 Gr. 5	5 1/2"
104-3524	1 1/2" Rd. 3/8" Kw.	(2) 3/8" - 16 Gr. 5	6"

Replacement Shear Bolt Part No. 11-10445

Quick Disconnect

Repair Kit —
*13002021
**13002006
***13002020
****13002806

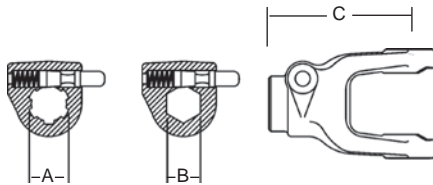

Stock Number	Dim. "A" Bore	Dim. "B" Bore	Dim. "C"
102-3505*		1 1/4" Hex	4 3/4"
102-3506**	1 3/8" x 6 Spl.		4 3/4"
102-3518*		1 1/8" Hex	4 3/4"
102-3520***	1 3/4" x 20 Spl.		5 3/8"
102-3521*	1 3/8" x 21 Spl.		4 3/4"
102-3528****	1 3/4" x 6 Spl.		5 5/16"

Auto-Lok

Repair Kit —
*13004000
**13004020

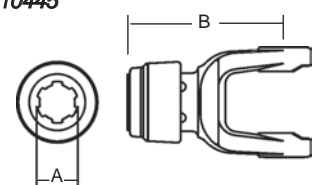

Stock Number	Dim. "A" Bore	Dim. "B"
110-3506*	1 3/8" x 6 Spl.	5 1/4"
110-3520**	1 3/4" x 20 Spl.	6 1/8"
110-3521*	1 3/8" x 21 Spl.	5 1/4"

Cross & Bearing Kit

(R Kit)
(Recommended 8 hour grease interval)

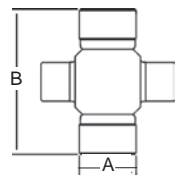

Snap Ring Located in Yoke

Stock Number	Dim. "A"	Dim. "B"
200-3500	1 1/4"	3 7/32"

Extended Lubrication Cross & Bearing Kit (E Kit)

(Recommended 50 hour grease interval)

Snap Ring Located in Yoke

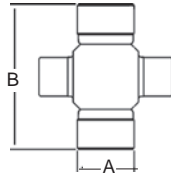

Stock Number	Dim. "A" Bore	Dim. "B"
201-3500	1 1/4"	3 7/32"

Slip Sleeve

With Grease Groove

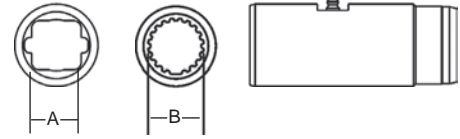

Stock Number	Length	Dim. "A" Bore	Dim. "B" Bore	Fits Tube Size
500-3500	5"	1 3/16" Sq.		2 1/8" (.120 Wall)
501-3500	5"	1 3/16" Sq.		2 1/8" (.083 Wall) & 2 1/4" (.120 Wall)
504-3500	8"	1 5/16" Sq.		2 1/2" (.120 Wall)
505-3500	5"		1 11/16" x 20 Spl.	2 1/2" (.120 Wall)

Shaft Weld Yoke

With Bearing Groove

(Guard must rotate freely on yoke)

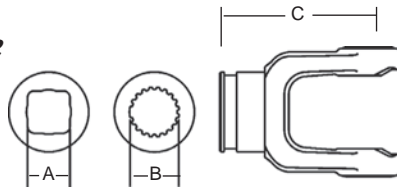

Stock Number	Dim. "A" Bore	Dim. "B" Bore	Dim. "C"
300-3500	1 3/16" Sq.		4 1/4"
301-3500		1 5/16" x 20 Spl.	4 1/4"
*302-3500		1 11/16" x 20 Spl.	3 3/4"

* For use with 921-3500 Nylon Bearing Kit and 902-3548 / 902-3560 Guard

Spline Sleeve

With Grease Reservoir

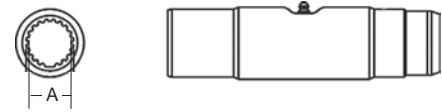

Stock Number	Length	Dim. "A" Bore	Fits Tube Size
502-3500	8"	1 5/16" x 20 Spl.	2 1/8" (.120 Wall)
503-3500	8"	1 11/16" x 20 Spl.	2 1/2" (.120 Wall)

Shaft

1 3/16" Square



Stock Number	Length
400-0019	6'
404-0019	3'

Tube



Stock Number	Dim. "A" Size	Length
602-3500	2 1/8" (.120 Wall)	6'
604-3500	2 1/8" (.120 Wall)	3'

Spline Shaft

Induction Hardened



Stock Number	Dim. "A" Size	Length	Major Dim.
404-2120	1 5/16" x 20 Spl.	3'	1.380/1.375
404-2720	1 11/16" x 20 Spl.	3'	1.790/1.785

Tube Weld Yoke

With Bearing Groove
(Guard must rotate freely on yoke)

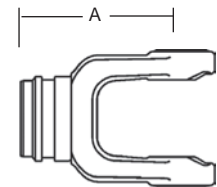

Stock Number	Dim. "A"	Fits Tube Size
701-3500	4 1/4"	2 1/8" (.120 Wall)
702-3500	4 1/4"	2 1/8" (.083 Wall)
703-3500 with Bore**	4 1/4"	2 1/4" (.120 Wall)
*704-3500 with Bore**	4 1/4"	2 1/2" (.120 Wall)
705-3500 with Bore**	4 1/4"	2 1/8" (.120 Wall)

* For use with 921-3500 Nylon Bearing Kit and 902-3548 / 902-3560 Guard

** Bore through for telescoping shaft

35 Series (cont'd.)

Implement Yoke

Round Bore

With Keyway & Set Screw

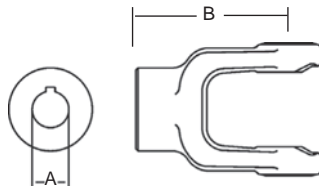

Stock Number	Dim. "A" Bore	Standard Keyway	Dim. "B"
800-3516	1"	1/4"	4 1/4"
800-3518	1 1/8"	1/4"	4 1/4"
800-3519	1 3/16"	1/4"	4 1/4"
800-3520	1 1/4"	1/4"	4 1/4"
800-3522	1 3/8"	5/16"	4 1/4"
800-3523	1 7/16"	3/8"	4 1/4"
800-3524	1 1/2"	3/8"	4 1/4"
8003524H	1 1/2"	3/8" with 5/16" Pinhole	4 1/4"
800-3528	1 3/4"	3/8"	4 1/4"
800-3526	1 5/8"	3/8"	4 1/4"

Square Bore

With Set Screw

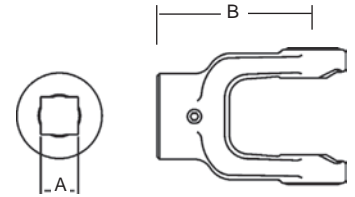

Stock Number	Dim. "A" Bore	Dim. "B"
804-3516	1"	4 1/4"
804-3518	1 1/8"	4 1/4"
804-3519	1 3/16"	4 1/4"
804-3520	1 1/4"	4 1/4"
804-3524	1 1/2"	4 1/4"

Spline Bore

With 21/64" Pin Hole

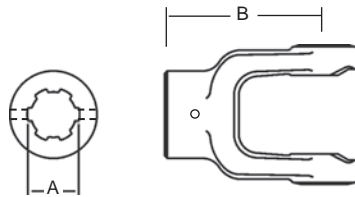

Stock Number	Dim. "A" Bore	Dim. "B"
801-3506	1 3/8" x 6 Spl.	4 1/4"
801-3521	1 3/8" x 21 Spl.	4 1/4"

Round Bore

Double Keyway & Set Screw

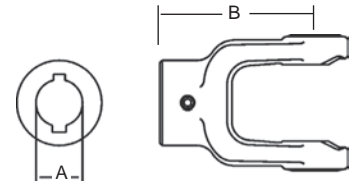

Stock Number	Dim. "A" Bore	Dim. "B"	Double Keyway
806-3519	1 3/16"	4 1/4"	1/4" & 5/16"
806-3520	1 1/4"	4 1/4"	1/4" & 5/16"
806-3522	1 3/8"	4 1/4"	5/16" & 3/8"

Shear Pin

With 1/4" Pin Hole

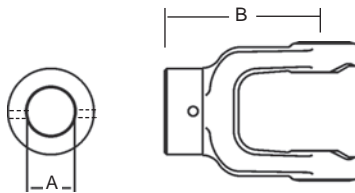

Stock Number	Dim. "A" Bore	Dim. "B"
802-3520	1 1/4"	4 1/4"
802-3522*	1 3/8"	4 1/4"
802-3524	1 1/2"	4 1/4"

* With 1/2" Pin Hole.

Clamp Yoke

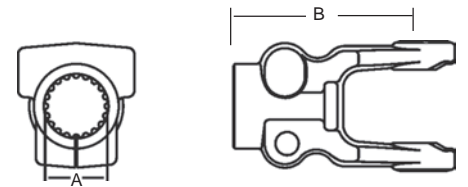

Stock Number	Dim. "A" Bore	Dim. "B"
807-3506	1 3/8" x 6 Spl.	4 3/4"
807-3520	1 3/4" x 20 Spl.	5 3/8"
807-3521	1 3/8" x 21 Spl.	4 3/4"
807-3527	1 3/4" x 27 Spl.	5 1/4"

Torque Limiter Flange

(Interchanges with Great Lakes Clutch)

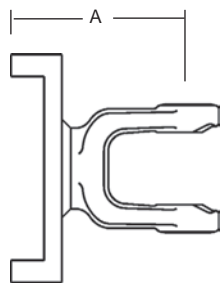

Stock Number	Dim. "A"
803-3500	5"

Stock Bore

With Hub O. D. Turned

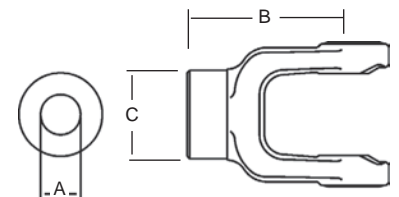

Stock Number	Dim. "A" Bore	Dim. "B"	Dim. "C"
809-3516	1"	4 1/4"	2 1/4"

Guard

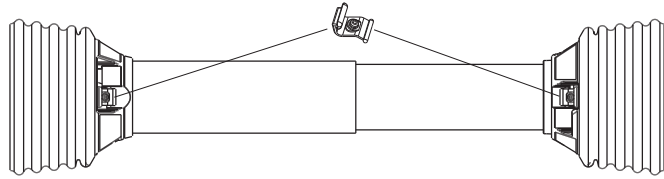

Order Bearings As Required

Stock Number	Overall Driveline Length	Bearing Kit (4-per kit)
900-2548	48"	921-1200
900-2560	60"	921-1200

Assembly instructions included with guard bearing kit
NOTE: Guards must rotate freely on yokes

Easy Lock™ Replacement Kit

Part Number: 13005000 (4-per Kit)



Yoke & Shaft Assembly

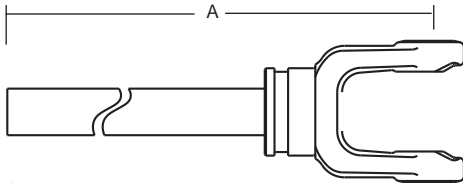

1 3/16" Square Shaft

Stock Number	Dim. "A"
10003531	17.69"
10003535	21.69"
10003542	28.69"
10003548	33.19"
10003560	44.94"

Guard Chain Kit

Insert the "S" hook through the guard loop and crimp shut



Part Number: 13006500 (2-per Kit)

Universal Joint

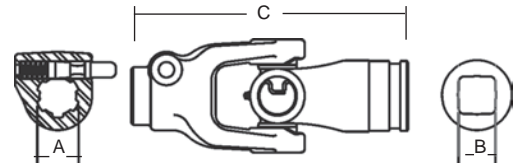

Quick Disconnect to Shaft Weld Yoke
Repair Kit — 13002006

Stock Number	Dim. "A" Bore	Dim. "B" Bore	Dim. "C"
15063500	1 3/8" × 6 Spl.	1 3/16" Sq.	8 7/8"

Yoke, Tube & Sleeve Assembly

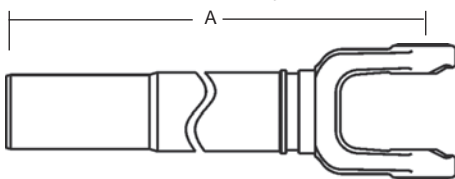

1 3/16" Square

Stock Number	Dim. "A"
11003531	17.69"
11003535	21.69"
11003543	29.69"
11003548	34.69"
11003560	46.69"

35 Series (cont'd.)

Drivelines

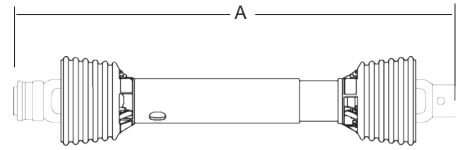
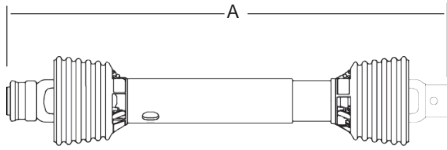

Drivelines are furnished without Cross & Bearing Kit and Implement Yoke. Select kit and yoke as required. When cross & bearing kit and yoke are assembled, the overall compressed length of the driveline will be 31", 35", 48" or 60".

Drivelines are furnished without Cross & Bearing Kit and Outboard Yokes. Select kit and outboard yokes as required. When cross & bearing kit and outboard yokes are assembled, the overall compressed length of the driveline will be 39", 48" or 60".

Stock Number	Tractor Yoke	Overall Compressed Length Dim. "A"	Max Running Length
14003531	1 3/8" x 6 Spl. Q.D.	31"	40"
14003535	1 3/8" x 6 Spl. Q.D.	35"	47"
14003548	1 3/8" x 6 Spl. Q.D.	48"	72"
14003560	1 3/8" x 6 Spl. Q.D.	60"	96"

Stock Number	Overall Compressed Length Dim. "A"	Max Running Length
14013548	48"	72"
14013560	60"	96"
14023539 (with crosses installed)	39"	51"
14023548 (with crosses installed)	48"	72"

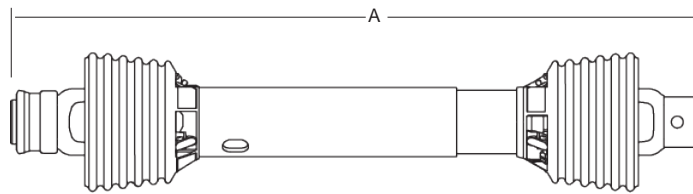

Stock Number	Tractor Yoke	Implement Yoke	Overall Compressed Length Dim. "A"	Max. Running Length	Application
14003507	1 3/8" x 6 Spl. Q.D.	1 3/8" Round 1/2" Shear Pin Hole	64 7/8"	88 7/8"	7 ft. Pull Type Rotary Cutter
14003524	1 3/8" x 6 Spl. Q.D.	1 1/2" Round 3/8" Keyway	48"	71 3/4"	Pumps
14003536	1 3/8" x 6 Spl. Safety Slide Lock	1 3/8" x 6 Spl. Safety Slide Lock	36"	47 3/4"	All Purpose
14013531	1 3/8" x 21 Spl. Safety Slide Lock	1 1/8" Hex Clamp	31"	44"	Combine Header